

RATED CAPACITY MANUAL

MODEL MAC 25

16.6t REAR AXLE WEIGHT
BOOK PART NUMBER MXC1347B

HYDRAULIC ALL TERRAIN PICK & CARRY CRANE

"SUPERLIFT"

25 TONNE MAXIMUM RATED CAPACITY



Do not operate this crane unless you have read and understood the information in this book.

MXC1347B
RATED CAPACITY MANUAL
MAC 25 (STANDARD 1500kg COUNTERWEIGHT + EXTRA
2160kg COUNTERWEIGHT)

ALL PAGES LISTED MUST BE INCLUDED IN THIS BOOK.

SECTION 1 - WARNINGS	3
DEFINITIONS	4
OPERATION ON SIDE SLOPES	8
SIDE SLOPE DERATION CHART	9
SECTION 2 - OPERATIONS	11
RANGE DIAGRAM	11
WORKING AREA DIAGRAM.....	11
DETACHABLE COUNTERWEIGHT	12
ATTACHMENT MASSES	12
HOOK BLOCK RATED CAPACITY.....	12
ROPE SPECIFICATIONS.....	13
TYRE SPECIFICATIONS	13
TYRE INFLATION	13
SECTION 3 – LIFTING CAPACITY	14
RANGE DIAGRAM	14
LOAD MOMENT INDICATOR DUTIES	15
1500 kg COUNTERWEIGHT ON FRONT	15
1500 kg COUNTERWEIGHT ON REAR	15
1500+2160 kg COUNTERWEIGHT ON REAR	15

SECTION 1 - WARNINGS



DANGER

IMPROPER CRANE USE, CARE OR OPERATION CAN CAUSE INJURY, DEATH OR PROPERTY DAMAGE.

DO NOT OPERATE THIS MACHINE UNLESS YOU HAVE READ AND UNDERSTAND THE OPERATOR'S MANUAL AND CRANE RATED CAPACITY MANUAL.

COPIES OF OPERATOR'S MANUALS AND CRANE RATED CAPACITY MANUAL MAY BE OBTAINED FROM:



TEREX®



CAUTION

WRITTEN AUTHORISATION IS REQUIRED FROM TEREX LIFTING AUSTRALIA PTY LTD PRIOR TO THE USE OF ANY ATTACHMENT NOT SPECIFIED IN THE MANUAL.

DEFINITIONS

Articulation – The crane pivots in the middle to allow steering and slewing of the load. Working Areas for the purpose of determining Rated Capacity are less than 10° Articulation, and greater than 10° Articulation, in either direction, from straight ahead. Up to 40° Articulation is possible in either direction. See Working Area diagram

Deration – A decrease in the Rated Capacity due to external influences, expressed as a percentage.

Freely Suspended Load – Load hanging free with no direct external force applied except by the winch rope.

Load Radius – Horizontal distance from the centre of the front wheels forwards to the centre of the winch rope or tackle with load applied. "Radius" on Rated Capacity charts refers to the Load Radius in metres.

Loaded Boom Angle – This is given to assist in setting up the crane only. It gives only an approximation of the Load Radius for a specified boom length. No allowance is made for boom or tyre deflection. "Boom Angle" on Rated Capacity charts refers to the Loaded Boom Angle in degrees.

Load Moment Indicator (LMI) - A system which indicates, visually and audibly, to the operator when the Rated Capacity is approached and reached.

Rated Capacity (RC) – The total Freely Suspended Load, including the mass of material and load handling equipment, that the machine can safely lift under ideal conditions at a given boom length and Load Radius.

Side Load – Any external force applied either to the boom or load in a horizontal direction.

Work Areas – Area measured in an arc about the centre pivot as shown on the Working Area diagram. The "Articulation (green/amber)" icon on the LMI indicates which zone the crane is in. Green indicates less than 10° Articulation. Amber indicates greater than 10° Articulation.



DANGER

4. Rated Capacities above the red line are based on the machine's hydraulic or structural competence and not on machine stability. Rated Capacities below the red line are based on machine stability.
5. Rated Capacities include the mass of hooks, blocks, slings and auxiliary lifting devices. Their mass must be subtracted, from the listed Rated Capacity, to determine the equivalent net load.
6. Loaded Boom Angles at specified boom lengths give only an approximation of the Load Radius. The Boom Angle before loading should be greater to account for boom deflection increasing the Load Radius as the load is lifted.

OPERATION

1. Read and understand all warnings and instructional notes.
2. Do not tip the machine to determine allowable lifting capacities.
3. Loads may be lifted from the main boom head on the winch, the rhino hook, the fixed lug, or either of the two sliding lugs on the boom. A flyjib is also available to extend the maximum boom length and a manbasket can be pinned to the head of the boom. Always use the correct Rated Capacity chart for the lifting point in use and ensure the LMI is set to the correct duty. Written authorisation from Terex Lifting Australia Pty Ltd is required prior to the use of any attachment not specified in the manual.
4. Lifting from more than one lifting point simultaneously is neither intended nor approved.
5. Handling of personnel from the boom is neither intended nor approved, except in a Terex Lifting Australia supplied manbasket, correctly installed on the head of the boom, or other approved arrangement.
6. When either the boom length or Load Radius or both are between values listed, the smallest load shown at either the next larger Load Radius or boom length shall be used, or the interpolated value shown on the LMI may be used.
7. Side Loading of the machine and load swing out may cause structural failure or machine tip-over. Side Loads may be generated by: lifting when not level; sudden acceleration or deceleration in Articulating with a load; dragging a load; pushing a load; wind forces on load and boom structure and unstable ground.
8. It is safe to attempt to telescope any load within the limits of the Rated Capacity Manual. The maximum load that may be telescoped is limited by hydraulic pressure, Loaded Boom Angle and powered boom sections lubrication.



DANGER

SPECIAL PRECAUTIONS FOR ARTICULATED CRANES

THERE IS A POTENTIAL FOR CRUSHING BETWEEN FRONT AND REAR CHASSIS WHEN THE MACHINE ARTICULATES. NEVER STAND IN THE PIVOT AREA WHEN THE ENGINE IS RUNNING OR EMERGENCY STEERING PUMP IS OPERATING. ALWAYS REMOVE THE KEY FROM THE IGNITION BEFORE WORKING IN THE PIVOT AREA.

DO NOT LEAVE IGNITION KEY SWITCHED ON WITH ENGINE STOPPED AND PARK BRAKE OFF, AS EMERGENCY HYDRAULIC STEERING PUMP WILL ACTIVATE.

GENERAL

1. This machine has been designed to meet the requirements of AS1418.1 & 1418.5 and has been tested in accordance with these standards for pick and carry operation on tyres.
2. Rated Capacities shown are for this machine as originally manufactured by Terex Lifting Australia Pty Ltd. The Rated Capacities only apply when all the instructions in this book are rigidly followed. Modifications to this machine or use of equipment other than that specified can result in a reduction in Rated Capacity.
3. If improperly operated or maintained, this machine can be hazardous. Operation and maintenance of this machine must be in compliance with the information documented in the operators, service and parts manuals furnished. If these manuals are missing, obtain replacements through Terex Lifting Australia Pty Ltd or their agents.
4. This machine is classified C3.

SET-UP

1. Reduced crane Rated Capacities for the particular job shall be established, by the operator, with due allowance for adverse operating conditions. These conditions include the supporting surface, pendulum action of the load, jerking or sudden stops of the load and other factors affecting stability, two machine lifts, electrical wires, adverse weather, wind, hazardous surroundings, experience of personnel, etc.
2. Rated Capacity is based on Freely Suspended Loads with the machine on a firm, level (max. 1% slope / 0.6°) and uniform surface. Lifting, or travelling with a load, on soft or uneven ground can be hazardous and will reduce the Rated Capacity of the crane. Refer to the "OPERATION ON SIDE SLOPES" in this manual. No attempt shall be made to drag the load along the ground in any direction.
3. Wind forces on the boom, resulting from winds up to 10 m/s (36 km/h), are incorporated in the Rated Capacity. Any additional Side Loading due to wind forces on the load will reduce the Rated Capacity, and must be considered.



CAUTION

9. The winch rope is fully compensated for boom extension. The only exception is when the third extension is being used. Refer to the operator's manual for information on the use of the third extension.
10. Do not allow the winch rope to unwind fully. Always ensure a minimum of 2 wraps of rope remain on the winch drum. Note the areas on the range diagram where the fall block cannot reach the ground on 6 parts of rope.
11. Rated Capacity depends on tyre rating, tyre condition and tyre inflation pressure. All tyres must be in good condition and must be inflated to the recommended pressure before attempting a lift.
12. Pick & carry operation is permitted through the full Articulation range, however, Rated Capacity is reduced above 10° Articulation. Use the reduced capacities in the rated capacity chart if entering this Articulation zone during the operation.
13. The maximum speed for pick & carry operation is 0.4m/s (1.44km/h). The transfer case shall be set to low range.
14. Operation of this crane in excess of the Rated Capacity and disregard of the instructions is hazardous.

OPERATION ON SIDE SLOPES

Mobile Cranes are primarily designed to be used on firm, flat, level ground (to within 1% gradient), according to AS 1418.5, any deviation from this requires that the Rated Capacity shall be reduced accordingly. As per AS 2550.5 – negotiation of slopes by mobile cranes travelling with Freely Suspended Loads should be avoided. The following precautions should be taken when operating on side slopes of up to 5° (8.75% gradient) – **REMEMBER** surface depressions and potholes will create the same effect as a side slope.

Ensure the tyres are correctly **INFLATED** as per the rated capacity manual.

Ensure the ground condition is **FIRM** enough to support the axle loads.

REDUCE the Rated Capacity of the crane by the percentage value for the crane as shown in figure 1 for operating on side slopes up to 5° (8.75% gradient) - **REMEMBER** the crane's load moment indicator will **NOT** automatically derate the Rated Capacity.

Use the crane's side slope inclinometer as a guide only, it is most accurate when the crane's Articulation is straight ahead without suspending a load. All Articulated chassis cranes will show some degree of side tilt, when Articulated with a load – this should not be confused with the ground's side slope.

Use the **MINIMUM** boom length and Loaded Boom Angle practical to keep the boom tip as close to the ground as possible.

Keep the load as **CLOSE** to the ground as possible.

Use the **MINIMUM** Articulation angle practical - **REMEMBER** the crane will side tilt and hence the hook will move towards the direction of Articulation whilst steering.

Keep the load on the **UPHILL** side of the crane where possible, especially when Articulated – **REMEMBER** the working Load Radius will increase if the load is suspended in the downhill position.

Load swing greatly reduces stability – **REMEMBER** to tagline loads to prevent pendulum motion of the load. Travel and crane motions should be applied gently to minimise this effect.

Sudden acceleration or deceleration of suspended load can also reduce stability – **REMEMBER** to travel gently to reduce load swing.

SIDE SLOPE DERATION CHART

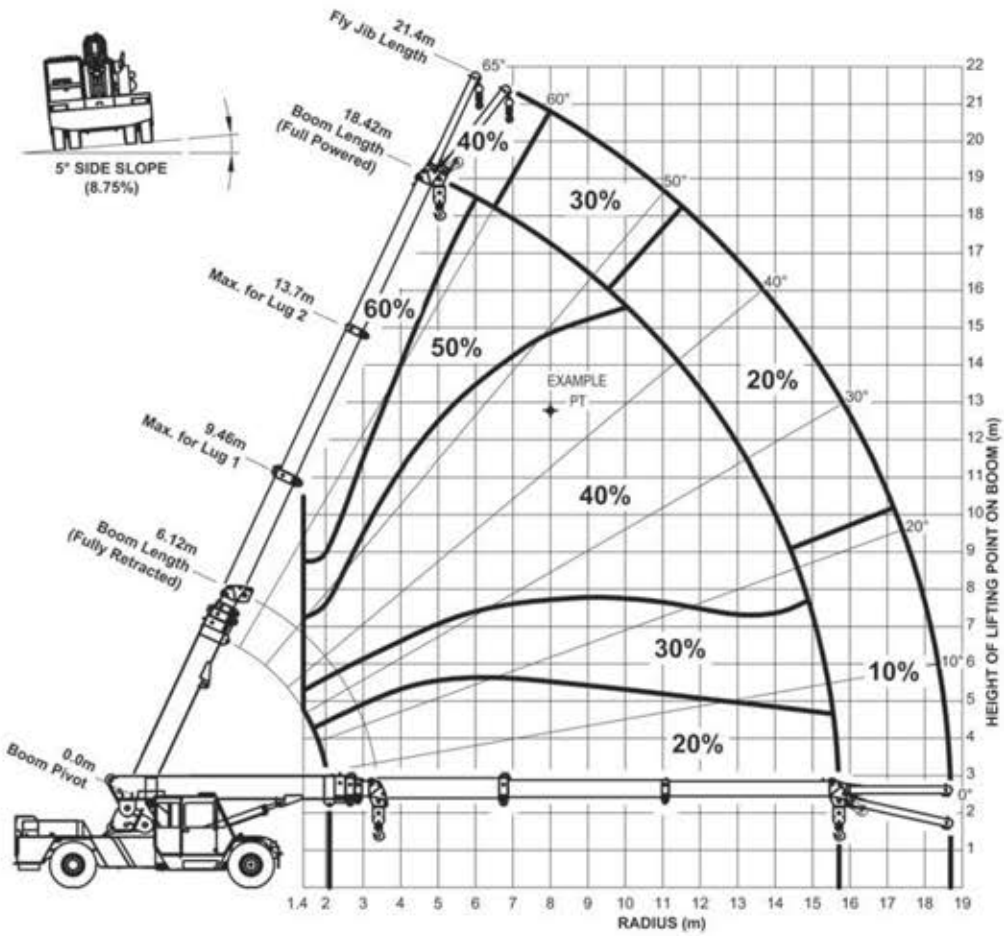

Figure 1: Percentage Deration Chart for MAC 25 at 5° Side Slope

NOTE

1. Percentage deration chart is based on 66.6% stability as per AS 1418.5 with the crane on a firm side slope of 5° (8.75% Gradient).
2. The percentage deration is dependent upon the location of the lifting point on the boom.
3. The percentage deration should be applied to the Rated Capacity as read off the Rated Capacity chart for the applicable boom length, Loaded Boom Angle, Load Radius, Articulation Angle and Counterweight Position. See over page for an example.

Example (For MAC 25 Crane, Rated Capacity manual MXC1347B): See Percentage Deration Chart for

Lifting condition:-

Boom Length: 15.0 m
Loaded Boom Angle: 45°
Load Radius: 8.0 m
Articulation Angle: Greater than 10°
Counterweight: Fitted on rear of crane

RC (Level ground): 3700 kg (From Load Chart MXC1268A, for above lifting conditions)

Percentage Deration: 40 % (From Figure 1: Percentage Deration Chart)

$$\begin{aligned} \text{RC (5° Slide Slope)} &= \text{RC (as per Rated Capacity chart)} - \text{Percentage Deration} \\ &\quad \times \text{RC (as per Rated Capacity chart)} / 100 \% \\ &= 3700 \text{ kg} - 40\% \times 3700 \text{ kg} / 100\% \\ &= 2220 \text{ kg} \end{aligned}$$

SECTION 2 - OPERATIONS

RANGE DIAGRAM

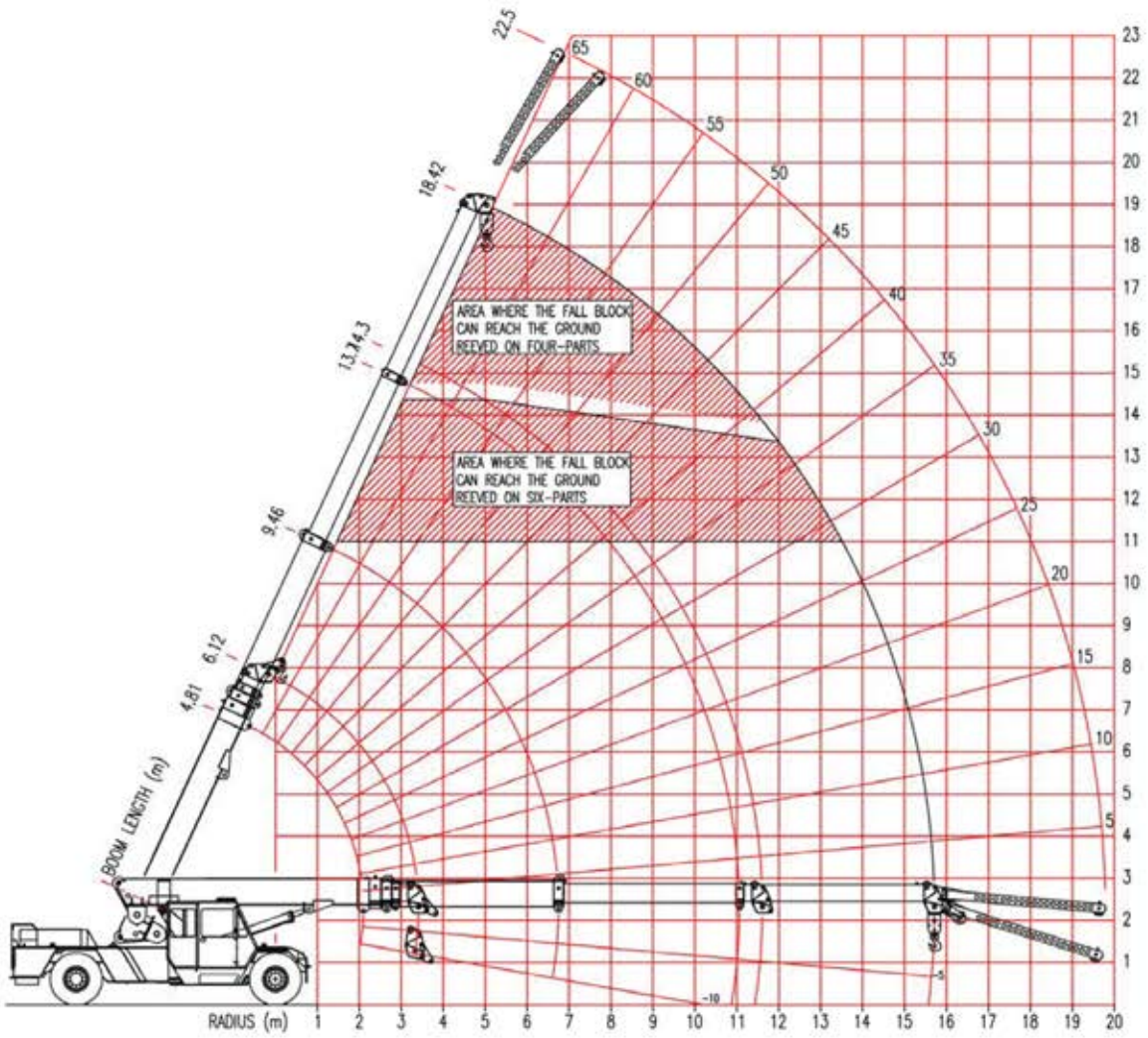

WORKING AREA DIAGRAM

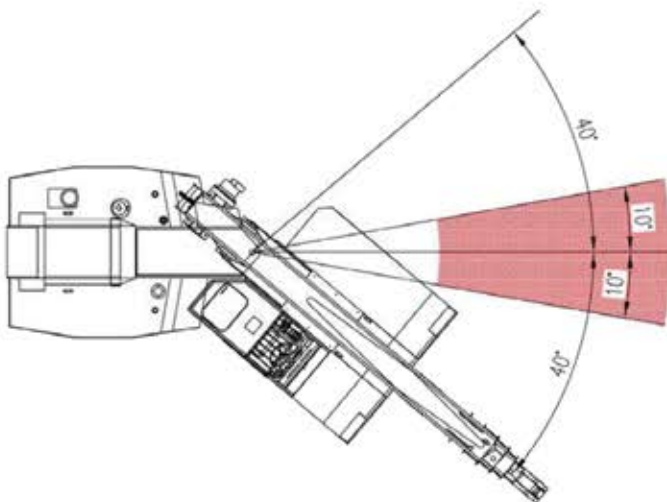

DETACHABLE COUNTERWEIGHT

WEIGHT: 1500kg

TO BE FRONT MOUNTED FOR ROAD TRAVEL

PART NO: PLMXF2034

EXTRA COUNTERWEIGHT: 2160kg

NOT TO BE FITTED FOR ROAD TRAVEL

PART NO: PLMXF2019

ATTACHMENT MASSES

FOUR/SIX PART FALL BLOCK	PLMXA3018	180 kg
FOUR/SIX PART FALL BLOCK	PLMXA3033	230 kg
25 T HOOK	PP2087500	20 kg
9 T HOOK	PP2190200	10 kg
SINGLE PART HOOK BLOCK	PL16M2090	30 kg
RHINO HOOK	PLMXF3015	25 kg
12 METRIC TONNE SPREADER BAR	PL16A3035	94 kg
15 METRIC TONNE SPREADER BAR	PL15A8023	107 kg

NOTE: THESE MASSES APPLY ONLY TO TEREX LIFTING AUSTRALIA PTY LTD SUPPLIED EQUIPMENT.

HOOK BLOCK RATED CAPACITY

Number of Parts of Rope	Permissible HOOK BLOCK RC (kg)
1	4 200
2	8 400
4	16 800
6	25 000

ROPE SPECIFICATIONS

WIRE ROPE:

Ø14mm

35W x 7 NR 2070 MPa

MINIMUM BREAKING FORCE 165 kN

MACHINE SPLICE & THIMBLE EYE ONE END ONLY

LENGTH - 110m

RETRACT ROPE:

Ø11mm

6 x 25 WRC G2070

MINIMUM BREAKING FORCE 82.4kN

EXTENSION CHAIN:

BL1066 LEAF CHAIN

MINIMUM BREAKING FORCE 40 000 KGF

TYRE SPECIFICATIONS

Type	Condition	Speed	Load Rating
14.00 x 20 Dual Tyres	Pick & Carry	<1.44 km/h	10500 kg per tyre at 830 kPa (120 psi) (dual fitment)
	Highway	80 km/h	3050 kg per tyre at 620 kPa (90 psi) (dual fitment)

TYRE INFLATION

Type	Position	Inflation Pressure	
		Pick & Carry	Highway Travel
14.00 x 20 Dual Tyres	Front	830 kPa (120 psi) (Max RC 25 tonne)	830 kPa (120 psi)
	Rear	620 kPa (90 psi)	620 kPa (90 psi)

SECTION 3 – LIFTING CAPACITY

RANGE DIAGRAM

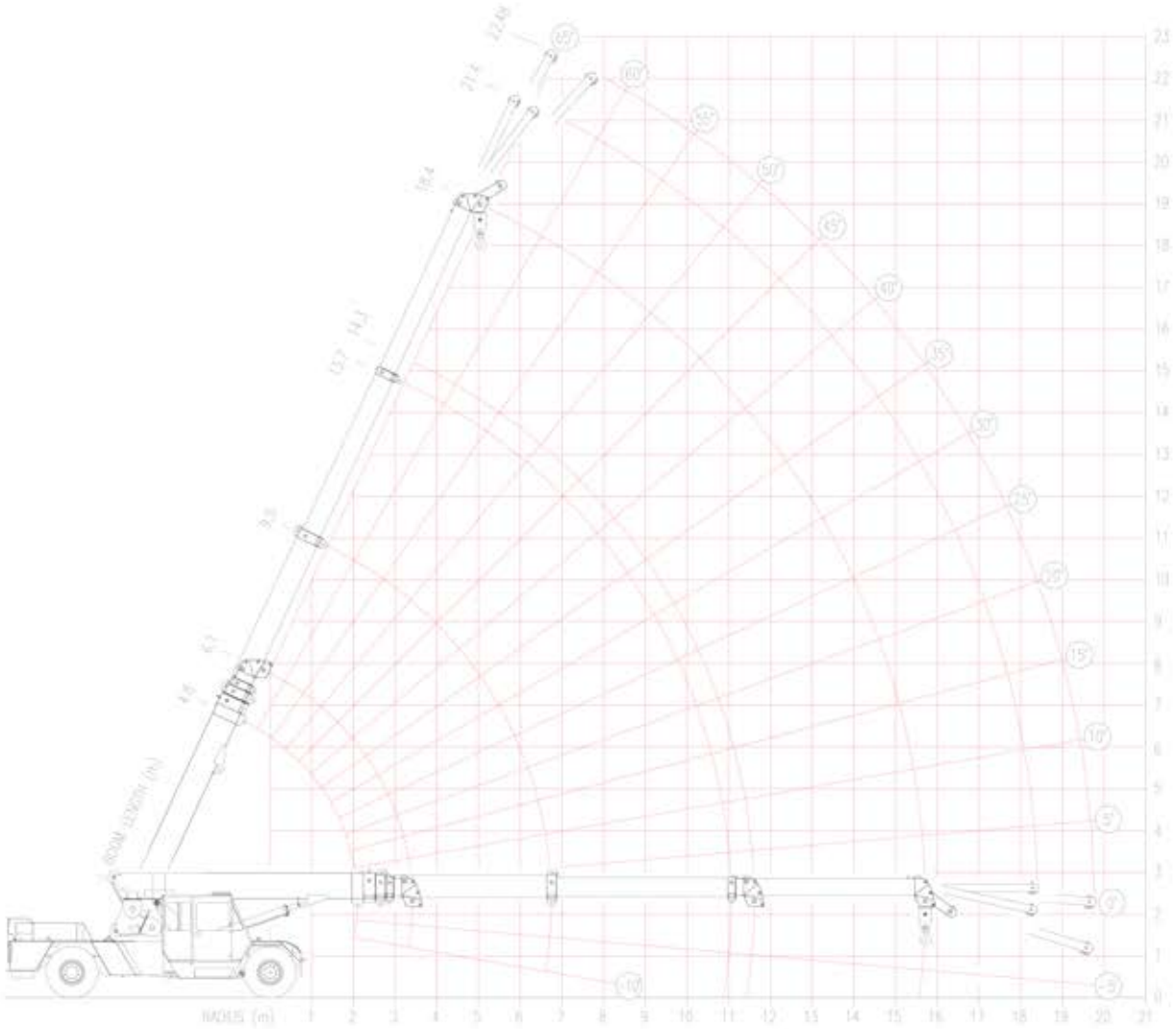

CONDITIONS:

FRONT SPRING LOCKOUTS TO BE ENGAGED FOR ALL LIFTING AND PICK AND CARRY OPERATIONS.

LOAD MOMENT INDICATOR DUTIES

1500 kg COUNTERWEIGHT ON FRONT

DUTY	DESCRIPTION
101	FALL BLOCK
102	RHINO HOOK
103	OFFSET HEAD – BOTTOM POSITION
104	OFFSET HEAD – TOP POSITION
105	3M FLYJIB –TOP POSITION - 0° OFFSET
106	3M FLYJIB –TOP POSITION – 12.5° OFFSET
107	4M FLYJIB – TOP POSITION - 5° OFFSET
108	4M FLYJIB – BOTTOM POSITION – 17.5° OFFSET
109	MAN BASKET
110	BUTT LUG
111	LUG 1 – BOOM 1
112	LUG 2 – BOOM 2

1500 kg COUNTERWEIGHT ON REAR

DUTY	DESCRIPTION
201	FALL BLOCK
202	RHINO HOOK
203	OFFSET HEAD – BOTTOM POSITION
204	OFFSET HEAD – TOP POSITION
205	3M FLYJIB –TOP POSITION - 0° OFFSET
206	3M FLYJIB –TOP POSITION – 12.5° OFFSET
207	4M FLYJIB – TOP POSITION - 5° OFFSET
208	4M FLYJIB – BOTTOM POSITION – 17.5° OFFSET
209	MAN BASKET
210	BUTT LUG
211	LUG 1 – BOOM 1
212	LUG 2 – BOOM 2

1500+2160 kg COUNTERWEIGHT ON REAR

DUTY	DESCRIPTION
301	FALL BLOCK
302	RHINO HOOK
303	OFFSET HEAD – BOTTOM POSITION
304	OFFSET HEAD – TOP POSITION
305	3M FLYJIB –TOP POSITION - 0° OFFSET
306	3M FLYJIB –TOP POSITION – 12.5° OFFSET
307	4M FLYJIB – TOP POSITION - 5° OFFSET
308	4M FLYJIB – BOTTOM POSITION – 17.5° OFFSET
309	MAN BASKET
310	BUTT LUG
311	LUG 1 – BOOM 1
312	LUG 2 – BOOM 2

MAC-25 FALL BLOCK LOAD CHART - 10 DEG. ART.

LMI DUTY

301

STANDARD 1500 KG COUNTERWEIGHT (PLMXF2009) + EXTRA 2160 KG COUNTERWEIGHT (PLMXF2019-) ON REAR OF CRANE - SPRING LOCKOUTS ENGAGED

RC IN KILOGRAMS FOR SLEW ANGLES OF 10 DEGREES OR LESS EITHER SIDE OF STRAIGHT AHEAD (INDICATED BY GREEN LED ON DASH).
BOOM ANGLE - UNDEFLECTED (REF.)

RC ABOVE BOLD RED LINE ARE STRUCTURAL
 RC ARE BASED ON FIRM LEVEL GROUND (1% SLOPE (0.6 DEG) AS PER AS1418.5) WITH TYRES INFLATED AS PER NOTES

NOTE: VALUES IN BRACKETS () ARE ACTUAL RADIUS AT ZERO DEG. BOOM ANGLE.
 RC ARE BASED ON 66.6% STABILITY & STRENGTH

LIFT & CARRY - THE RC SHALL BE CARRIED WITH THE MINIMUM BOOM LENGTH & AS CLOSE TO THE GROUND AS POSSIBLE AT SPEEDS NOT IN EXCESS OF 0.4 m/s (1.44 km/h)

Radius in Metres	BOOM PIVOT TO HEAD SHEAVES - THIRD BOOM RETRACTED (metres)																	THIRD BOOM EXTENDING (metres)										
	6.12	6.50	7.00	7.50	8.00	8.50	9.00	9.50	10.00	10.50	11.00	11.50	12.00	12.50	13.00	13.50	14.32	14.50	15.00	15.50	16.00	16.50	17.00	17.50	18.00	18.42		
1.4	25000	25000	25000	25000	25000	25000	25000	25000																				
2.0	23400	23400	23250	23350	23350	23300	23300	23300	23250	22150	19300																	
2.5	21450	21400	21350	21350	21300	21250	21250	21200	21200	20450	17750	15550	14600															
3.0	17600	17600	17600	17550	17500	17500	17450	17450	17400	17400	16500	14350	13500	13000	12600	12250												
3.5	15250	14850	14850	14850	14800	14800	14750	14750	14750	14700	14700	13350	12600	12150	11750	11400	10850	10750										
4.0		13600	12800	12800	12800	12750	12750	12750	12700	12700	12700	12550	11750	11350	10950	10600	10100	10050	9850	9650								
5.0			11800	10400	9900	9900	9900	9900	9900	9850	9850	9850	9800	9650	9350	8900	8800	8650	8500	8400	8250	8150	8000	7900				
6.0					9250	8300	8000	8000	8000	8000	7950	7950	7950	7950	7950	7900	7900	7900	7900	7750	7600	7450	7350	7200	7100	7000	6950	
7.0							7500	6850	6600	6600	6600	6600	6600	6600	6600	6550	6600	6600	6650	6700	6600	6500	6400	6300	6250			
8.0																												
9.0																												
10																												
11																												
12																												
13																												
14																												
15																												
15.71																												

WINCH RC	
SINGLE PART	4200
TWO PARTS	8400
FOUR PARTS	16800
SIX PARTS	25000

NOTE : WEIGHT OF HOOKS, BLOCKS & OTHER LOAD HANDLING DEVICES SHALL BE ADDED TO THE WEIGHT OF THE LOAD

MAC-25 RHINO HOOK LOAD CHART - 10 DEG

LMI DUTY

302

STANDARD 1500 KG COUNTERWEIGHT (PLMXF2009) + EXTRA 2160 DEG COUNTERWEIGHT (PLMXF2019-) ON REAR OF CRANE - SPRING LOCKOUTS ENGAGED

█ RC IN KILOGRAMS FOR SLEW ANGLES OF 10 DEGREES OR LESS EITHER SIDE OF STRAIGHT AHEAD (INDICATED BY GREEN LED ON DASH).
□ BOOM ANGLE - UNDEFLECTED (REF.)

RC ABOVE BOLD RED LINE ARE STRUCTURAL
 RC ARE BASED ON FIRM LEVEL GROUND (1% SLOPE (0.6 DEG) AS PER AS1418.5) WITH TYRES INFLATED AS PER NOTES

NOTE: VALUES IN BRACKETS () ARE ACTUAL RADIUS AT ZERO DEG. BOOM ANGLE.
 RC ARE BASED ON 66.6% STABILITY & STRENGTH

LIFT & CARRY - THE RC SHALL BE CARRIED WITH THE MINIMUM BOOM LENGTH & AS CLOSE TO THE GROUND AS POSSIBLE AT SPEEDS NOT IN EXCESS OF 0.4 m/s (1.44 km/h)

Radius in Metres	BOOM PIVOT TO HOOK CENTRE - THIRD BOOM RETRACTED (metres)																THIRD BOOM EXTENDING (metres)									
	6.45	7.00	7.50	8.00	8.50	9.00	9.50	10.00	10.50	11.00	11.50	12.00	12.50	13.00	13.50	14.00	14.65	15.00	15.50	16.00	16.50	17.00	17.50	18.00	18.50	18.75
1.4	15000	15000	15000	15000	15000	15000	15000																			
2.0	15000	15000	15000	15000	15000	15000	15000	15000	15000	15000																
2.5	15000	15000	15000	15000	15000	15000	15000	15000	15000	15000	15000	15000	14200													
3.0	15000	15000	15000	15000	15000	15000	15000	15000	15000	15000	15000	13200	12750	12300												
3.5	15000	15000	15000	14950	14950	14900	14900	14850	14850	14800	14000	12300	11850	11450	11150	10800										
4.0	13950	12950	12950	12900	12900	12850	12850	12800	12800	12750	11500	11100	10750	10400	10100	9750	9600	9450								
5.0		11950	10500	10000	10000	10000	10000	9950	9950	9950	9950	9900	9800	9500	9200	8900	8600	8500	8350	8200	8050	7900	7800	7700		
6.0		(4.3)	(4.8)	16	26	32	37	40	44	46	49	51	53	54	56	57	59	60	61	62	63	64	65			
7.0				9350	8400	8100	8100	8050	8050	8050	8050	8000	8000	8000	8000	7950	7650	7550	7400	7300	7200	7050	6950	6850	6800	6650
8.0				(5.3)	(5.8)	15	24	30	35	38	42	44	47	49	51	52	54	55	57	58	59	60	61	62	63	63
9.0						7600	6950	6700	6700	6700	6650	6650	6650	6650	6650	6650	6600	6650	6700	6550	6450	6350	6250	6200	6100	6050
10						(6.3)	(6.8)	15	23	29	33	37	40	42	45	47	49	50	52	53	55	56	57	58	59	60
11								6350	5850	5650	5650	5650	5650	5600	5600	5600	5650	5700	5750	5750	5700	5600	5550	5500		
12								(7.3)	(7.8)	14	22	28	32	35	38	41	44	45	47	49	50	52	53	54	55	56
13										5400	5000	4850	4850	4850	4850	4800	4800	4850	4900	4900	4950	4950	5000	5050	5050	5050
14										(8.3)	(8.8)	13	21	27	31	34	38	39	42	44	46	47	49	50	51	52
15												4600	4300	4200	4200	4200	4200	4200	4250	4300	4300	4350	4350	4400	4400	4450
16												(9.3)	(9.8)	13	20	26	31	33	36	38	40	42	44	46	47	48
17														4000	3750	3650	3650	3700	3700	3750	3800	3800	3850	3850	3900	3900
18														(10.3)	(10.8)	12	21	25	29	32	35	37	39	41	43	44
19																3500	3250	3250	3300	3300	3350	3400	3400	3450	3450	3450
20																(11.3)	(11.9)	12	19	24	28	31	34	36	39	
21																		3100	2950	2950	3000	3000	3050	3050	3100	3100
22																		(12.3)	(12.8)	12	18	23	27	30	33	34
23																				2850	2700	2700	2700	2750	2800	2800
24																				(13.3)	(13.8)	11	18	23	26	28
25																					2600	2500	2450	2500	2500	
26																					(14.3)	(14.8)	11	17	20	
27																							2400	2300	2250	
28																							(15.3)	(15.8)	(16.)	

NOTE : WEIGHT OF HOOKS, BLOCKS & OTHER LOAD HANDLING DEVICES SHALL BE ADDED TO THE WEIGHT OF THE LOAD

MAC-25 RHINO HOOK LOAD CHART - 40 DEG

LMI DUTY

302

STANDARD 1500 KG COUNTERWEIGHT (PLMXF2009) + EXTRA 2160 KG COUNTERWEIGHT (PLMXF2019-) ON REAR OF CRANE - SPRING LOCKOUTS ENGAGED

RC IN KILOGRAMS FOR SLEW ANGLES OF GREATER THAN 10 DEGREES UP TO 40 DEGREES EITHER SIDE OF STRAIGHT AHEAD (INDICATED BY RED LED ON DASH).
BOOM ANGLE - UNDEFLECTED (REF.)

RC ABOVE BOLD RED LINE ARE STRUCTURAL
 RC ARE BASED ON FIRM LEVEL GROUND (1% SLOPE (0.6 DEG) AS PER AS1418.5)
 WITH TYRES INFLATED AS PER NOTES

NOTE: VALUES IN BRACKETS () ARE ACTUAL RADIUS AT ZERO DEG. BOOM ANGLE.
 RC ARE BASED ON 66.6% STABILITY & STRENGTH

LIFT & CARRY - THE RC SHALL BE CARRIED WITH THE MINIMUM BOOM LENGTH & AS CLOSE TO THE GROUND AS POSSIBLE AT SPEEDS NOT IN EXCESS OF 0.4 m/s (1.44 km/h)

Radius in Metres	BOOM PIVOT TO HOOK CENTRE - THIRD BOOM RETRACTED (metres)																THIRD BOOM EXTENDING (metres)										
	6.45	7.00	7.50	8.00	8.50	9.00	9.50	10.00	10.50	11.00	11.50	12.00	12.50	13.00	13.50	14.00	14.65	15.00	15.50	16.00	16.50	17.00	17.50	18.00	18.50	18.75	
1.4	15000	15000	15000	15000	15000	14350	13700																				
	51	55	58	60	62	64	65																				
2.0	15000	15000	15000	14900	14000	13250	12600	12050	11550	11050																	
	44	49	52	55	57	59	61	63	64	65																	
2.5	15000	15000	15000	14100	13200	12450	11800	11250	10750	10300	9900	9550															
	37	43	47	50	53	56	58	59	61	63	64	65															
3.0	15000	15000	14150	13350	12450	11700	11050	10550	10050	9650	9250	8950	8600	8350													
	29	36	41	45	49	52	54	56	58	60	61	62	64	65													
3.5	13400	13400	13000	12250	11600	11000	10400	9850	9400	9000	8650	8350	8050	7800	7550	7300											
	17	29	35	40	44	47	50	52	55	56	58	60	61	62	63	64											
4.0	12400	11500	11500	11300	10650	10150	9750	9250	8850	8450	8100	7800	7550	7300	7050	6850	6600	6500	6350								
	(3.7)	18	28	34	39	43	46	49	51	53	55	57	58	60	61	62	63	64	65								
5.0	10600	9300	8900	8850	8800	8350	8000	7700	7450	7150	6900	6650	6400	6200	6050	5800	5700	5600	5500	5400	5300	5200	5150				
	(4.3)	(4.8)	16	26	32	37	40	44	46	49	51	53	54	56	57	59	60	61	62	63	64	65	65				
6.0				8300	7400	7100	7100	7050	6750	6500	6250	6050	5900	5700	5500	5350	5150	5100	5000	4900	4800	4750	4650	4600	4500	4500	
				(5.3)	(5.8)	15	24	30	35	38	42	44	47	49	51	52	54	55	57	58	59	60	61	62	63	63	
7.0						6700	6100	5850	5850	5750	5550	5350	5200	5050	4900	4750	4600	4550	4450	4400	4300	4250	4200	4100	4050	4050	
						(6.3)	(6.8)	15	23	29	33	37	40	42	45	47	49	50	52	53	55	56	57	58	59	60	
8.0										5550	5100	4950	4800	4650	4500	4350	4250	4100	4050	4000	3950	3900	3850	3800	3700	3650	3650
										(7.3)	(7.8)	14	22	28	32	35	38	41	44	45	47	49	50	52	53	54	55
9.0																											
10																											
11																											
12																											
13																											
14																											
15																											
16																											

NOTE : WEIGHT OF HOOKS, BLOCKS & OTHER LOAD HANDLING DEVICES SHALL BE ADDED TO THE WEIGHT OF THE LOAD

MAC-25 OFFSET HEAD BOTTOM POSITION LOAD CHART - 10 DEG

LMI DUTY

303

STANDARD 1500 KG COUNTERWEIGHT (PLMXF2009) + EXTRA 2160 KG COUNTERWEIGHT (PLMXF2019-) ON REAR OF CRANE - SPRING LOCKOUTS ENGAGED

RC IN KILOGRAMS FOR SLEW ANGLES OF 10 DEGREES OR LESS EITHER SIDE OF STRAIGHT AHEAD (INDICATED BY GREEN LED ON DASH).
BOOM ANGLE - UNDEFLECTED (REF.)

RC ABOVE BOLD RED LINE ARE STRUCTURAL
 RC ARE BASED ON FIRM LEVEL GROUND (1% SLOPE (0.6 DEG) AS PER AS1418.5) WITH TYRES INFLATED AS PER NOTES

NOTE: VALUES IN BRACKETS () ARE ACTUAL RADIUS AT ZERO DEG. BOOM ANGLE.
 RC ARE BASED ON 66.6% STABILITY & STRENGTH

LIFT & CARRY - THE RC SHALL BE CARRIED WITH THE MINIMUM BOOM LENGTH & AS CLOSE TO THE GROUND AS POSSIBLE AT SPEEDS NOT IN EXCESS OF 0.4 m/s (1.44 km/h)

Radius in Metres	BOOM PIVOT TO EDGE OF SHEAVE - THIRD BOOM RETRACTED (metres)																THIRD BOOM EXTENDING (metres)									
	6.86	7.00	7.50	8.00	8.50	9.00	9.50	10.00	10.50	11.00	11.50	12.00	12.50	13.00	13.50	14.00	14.50	15.06	15.50	16.00	16.50	17.00	17.50	18.00	18.50	19.16
1.4	8400	8400	8400	8400	8400	8400																				
	55	56	59	61	63	65																				
2.0	8400	8400	8400	8400	8400	8400	8400	8400	8400													WINCH RC				
	49	50	53	56	58	60	62	64	65													SINGLE PART		4200		
2.5	8400	8400	8400	8400	8400	8400	8400	8400	8400	8400	8400											TWO PARTS		8400		
	43	44	48	51	54	56	58	60	62	63	65															
3.0	8400	8400	8400	8400	8400	8400	8400	8400	8400	8400	8400	8400	8400													
	36	38	43	46	50	52	55	57	59	60	62	63	64	65												
3.5	8400	8400	8400	8400	8400	8400	8400	8400	8400	8400	8400	8400	8400	8400	8400											
	27	30	36	41	45	48	51	53	55	57	59	60	62	63	64	65										
4.0	8400	8400	8400	8400	8400	8400	8400	8400	8400	8400	8400	8400	8400	8400	8400	8400	8400									
	(4.2)	19	29	35	40	44	47	50	52	54	56	58	59	60	62	63	64	65								
5.0		8400	8400	8400	8400	8400	8400	8400	8400	8400	8400	8400	8400	8400	8400	8400	8400	8400	8400	8400	8350	8250	8100	8000		
		(4.3)	(4.8)	18	27	33	38	41	44	47	49	52	53	55	57	58	59	61	61	62	63	64	65			
6.0				8400	8400	8200	8200	8200	8150	8150	8150	8100	8100	8100	8100	8050	7950	7700	7600	7450	7350	7200	7100	7000	6500	5850
				(5.3)	(5.8)	17	25	31	36	39	42	45	47	49	51	53	54	56	57	58	59	60	61	62	63	64
7.0					7700	7050	6800	6800	6800	6750	6750	6750	6750	6700	6700	6700	6700	6700	6700	6700	6600	6500	6400	6300	6100	6050
					(6.3)	(6.8)	16	24	30	34	37	40	43	45	47	49	51	52	54	55	56	57	59	59	61	
8.0							6450	5900	5750	5750	5700	5700	5700	5700	5700	5700	5650	5700	5750	5800	5800	5800	5700	5650	5150	
							(7.3)	(7.8)	15	23	28	33	36	39	41	44	46	48	49	51	52	53	55	56	57	
9.0									5450	5050	4900	4900	4900	4900	4900	4900	4900	4900	4900	4950	5000	5000	5050	5050	4850	
									(8.3)	(8.8)	14	22	27	31	35	37	40	42	44	46	48	49	51	52	53	
10											4700	4350	4250	4250	4250	4250	4250	4250	4250	4300	4350	4350	4400	4400	4450	4450
											(9.3)	(9.8)	14	21	26	30	34	36	39	41	43	45	46	48	50	
11													4050	3800	3700	3700	3700	3750	3800	3800	3850	3850	3900	3900	3950	
													(10.3)	(10.8)	13	20	26	29	32	35	37	40	42	43	45	
12															3550	3350	3250	3300	3350	3400	3400	3450	3450	3500	3500	
															(11.3)	(11.8)	14	20	24	28	31	34	36	39	41	
13																	3100	3000	2950	3000	3050	3050	3100	3100	3150	
																	(12.4)	(12.8)	12	19	24	27	30	33	36	
14																			2850	2750	2700	2750	2750	2800	2800	
																			(13.3)	(13.8)	12	18	23	27	30	
15																					2600	2500	2500	2500	2550	
																					(14.3)	(14.8)	12	18	24	
16.4																							2400	2300	2200	
																							(15.3)	(15.8)	(16.4)	

MAC-25 OFFSET HEAD BOTTOM POSITION LOAD CHART - 40 DEG

LMI DUTY

303

STANDARD 1500 KG COUNTERWEIGHT (PLMXF2009) + EXTRA 2160 KG COUNTERWEIGHT (PLMXF2019) ON REAR OF CRANE - SPRING LOCKOUTS ENGAGED



RC IN KILOGRAMS FOR SLEW ANGLES OF GREATER THAN 10 DEGREES UP TO 40 DEGREES EITHER SIDE OF STRAIGHT AHEAD (INDICATED BY RED LED ON DASH).



BOOM ANGLE - UNDEFLECTED (REF.)

NOTE: VALUES IN BRACKETS () ARE ACTUAL RADIUS AT ZERO DEG. BOOM ANGLE.
RC ARE BASED ON 66.6% STABILITY & STRENGTH

RC ABOVE BOLD RED LINE ARE STRUCTURAL

RC ARE BASED ON FIRM LEVEL GROUND (1% SLOPE (0.6 DEG) AS PER AS1418.5)

WITH TYRES INFLATED AS PER NOTES

LIFT & CARRY - THE RC SHALL BE CARRIED WITH THE MINIMUM BOOM LENGTH & AS CLOSE TO THE GROUND AS POSSIBLE AT SPEEDS NOT IN EXCESS OF 0.4 m/s (1.44 km/h)

Radius in Metres	BOOM PIVOT TO EDGE OF SHEAVE - THIRD BOOM RETRACTED (metres)															THIRD BOOM EXTENDING (metres)										
	6.86	7.00	7.50	8.00	8.50	9.00	9.50	10.00	10.50	11.00	11.50	12.00	12.50	13.00	13.50	14.00	14.50	15.06	15.50	16.00	16.50	17.00	17.50	18.00	18.50	19.16
1.4	8400	8400	8400	8400	8400	8400																				
	55	56	59	61	63	65																				
2.0	8400	8400	8400	8400	8400	8400	8400	8400	8400																	
	49	50	53	56	58	60	62	64	65																	
2.5	8400	8400	8400	8400	8400	8400	8400	8400	8400	8400																
	43	44	48	51	54	56	58	60	62	63	65															
3.0	8400	8400	8400	8400	8400	8400	8400	8400	8400	8400	8400	8400	8400													
	36	38	43	46	50	52	55	57	59	60	62	63	64	65												
3.5	8400	8400	8400	8400	8400	8400	8400	8400	8400	8400	8400	8400	8150	7850	7600	7400										
	27	30	36	41	45	48	51	53	55	57	59	60	62	63	64	65										
4.0	8400	8400	8400	8400	8400	8400	8400	8400	8400	8400	8200	7900	7650	7400	7150	6900	6700	6500								
	(4.2)	19	29	35	40	44	47	50	52	54	56	58	59	60	62	63	64	65								
5.0	8400	8400	8400	8400	8400	8400	8400	8150	7850	7550	7250	7000	6750	6500	6300	6100	5950	5750	5650	5550	5450	5350	5250			
	(4.3)	(4.8)	18	27	33	38	41	44	47	49	52	53	55	57	58	59	61	61	62	63	64	65				
6.0			8400	7550	7250	7250	7150	6850	6600	6350	6150	6000	5750	5600	5400	5250	5100	5000	4950	4850	4750	4700	4600	4550	4450	
			(5.3)	(5.8)	17	25	31	36	39	42	45	47	49	51	53	54	56	57	58	59	60	61	62	63	64	
7.0				6800	6200	5950	5950	5850	5650	5450	5250	5100	5000	4850	4700	4550	4500	4400	4350	4300	4200	4150	4100	4000		
				(6.3)	(6.8)	16	24	30	34	37	40	43	45	47	49	51	52	54	55	56	57	59	59	61		
8.0						5650	5150	5000	5000	4900	4700	4550	4450	4300	4200	4100	4050	3950	3900	3850	3800	3750	3700	3650		
						(7.3)	(7.8)	15	23	28	33	36	39	41	44	46	48	49	51	52	53	55	56	57		
9.0								4750	4400	4250	4250	4150	4000	3900	3800	3650	3650	3600	3550	3500	3450	3400	3350	3300		
								(8.3)	(8.8)	14	22	27	31	35	37	40	42	44	46	48	49	51	52	53		
10									4050	3800	3700	3700	3550	3450	3300	3300	3250	3200	3150	3150	3100	3050	3000			
									(9.3)	(9.8)	14	21	26	30	34	36	39	41	43	45	46	48	50			
11										3500	3250	3200	3200	3050	3000	2950	2900	2900	2850	2850	2800	2750	2700			
										(10.3)	(10.8)	13	20	26	29	32	35	37	40	42	43	45	45			
12													3050	2850	2800	2800	2750	2700	2650	2600	2600	2550	2550			
													(11.3)	(11.8)	14	20	24	28	31	34	36	39	41			
13																2650	2550	2500	2500	2450	2400	2400	2350	2350		
																(12.4)	(12.8)	12	19	24	27	30	33	36		
14																	2400	2300	2300	2300	2250	2200	2150			
																	(13.3)	(13.8)	12	18	23	27	30			
15																			2200	2100	2100	2100	2000			
																			(14.3)	(14.8)	12	18	24			
16.4																					2000	1950	1850			
																					(15.3)	(15.8)	(16.4)			

NOTE: WEIGHT OF HOOKS, BLOCKS & OTHER LOAD HANDLING DEVICES SHALL BE ADDED TO THE WEIGHT OF THE LOAD

MAC-25 OFFSET HEAD TOP POSITION LOAD CHART - 10 DEG

LMI DUTY

304

STANDARD 1500 KG COUNTERWEIGHT (PLMXF2009) + EXTRA 2160 KG COUNTERWEIGHT (PLMXF2019-) ON REAR OF CRANE - SPRING LOCKOUTS ENGAGED

RC IN KILOGRAMS FOR SLEW ANGLES OF 10 DEGREES OR LESS EITHER SIDE OF STRAIGHT AHEAD (INDICATED BY GREEN LED ON DASH).
BOOM ANGLE - UNDEFLECTED (REF.)

RC ABOVE BOLD RED LINE ARE STRUCTURAL
 RC ARE BASED ON FIRM LEVEL GROUND (1% SLOPE (0.6 DEG) AS PER AS1418.5) WITH TYRES INFLATED AS PER NOTES

NOTE: VALUES IN BRACKETS () ARE ACTUAL RADIUS AT ZERO DEG. BOOM ANGLE.
 RC ARE BASED ON 66.6% STABILITY & STRENGTH

LIFT & CARRY - THE RC SHALL BE CARRIED WITH THE MINIMUM BOOM LENGTH & AS CLOSE TO THE GROUND AS POSSIBLE AT SPEEDS NOT IN EXCESS OF 0.4 m/s (1.44 km/h)

Radius in Metres	BOOM PIVOT TO EDGE OF SHEAVE - THIRD BOOM RETRACTED (metres)																	THIRD BOOM EXTENDING (metres)									
	6.82	7.00	7.50	8.00	8.50	9.00	9.50	10.00	10.50	11.00	11.50	12.00	12.50	13.00	13.50	14.00	14.50	15.02	15.50	16.00	16.50	17.00	17.50	18.00	18.50	19.12	
1.4	8400	8400	8400	8400	8400	8400	8400																				
	52	53	56	58	60	62	64																				
2.0	8400	8400	8400	8400	8400	8400	8400	8400	8400	8400																	
	45	47	50	53	56	58	60	61	63	64																	
2.5	8400	8400	8400	8400	8400	8400	8400	8400	8400	8400	8400	8400															
	39	41	45	49	52	54	56	58	60	61	63	64															
3.0	8400	8400	8400	8400	8400	8400	8400	8400	8400	8400	8400	8400	8400	8400	8400												
	32	34	40	44	47	50	53	55	57	58	60	61	63	64	65												
3.5	8400	8400	8400	8400	8400	8400	8400	8400	8400	8400	8400	8400	8400	8400	8400	8400	8400										
	24	27	33	38	42	46	49	51	53	55	57	59	60	61	62	63	64										
4.0	8400	8400	8400	8400	8400	8400	8400	8400	8400	8400	8400	8400	8400	8400	8400	8400	8400	8400									
	(4.1)	16	26	32	37	41	45	47	50	52	54	56	57	59	60	61	62	63	64								
5.0		8400	8400	8400	8400	8400	8400	8400	8400	8400	8400	8400	8400	8400	8400	8400	8400	8400	8400	8400	8400	8400	8300	8200	8050	7950	
		(4.3)	(4.8)	15	24	30	35	39	42	45	48	50	52	53	55	56	58	59	60	61	62	63	64	65			
6.0				8400	8400	8150	8150	8150	8100	8100	8050	8050	8050	8050	8000	8000	8000	7800	7650	7500	7400	7250	7150	7050	6950	6300	
				(5.3)	(5.8)	14	23	29	34	37	40	43	46	48	50	51	53	54	56	57	58	59	60	61	62	63	
7.0					7700	7000	6750	6750	6750	6700	6700	6700	6650	6650	6650	6650	6650	6650	6650	6700	6650	6500	6450	6350	6250	5850	
					(6.3)	(6.8)	14	22	28	32	36	39	41	44	46	48	50	51	53	54	55	56	57	58	59		
8.0							6400	5900	5700	5700	5700	5650	5650	5650	5600	5650	5700	5700	5700	5700	5750	5800	5750	5650	5450		
							(7.3)	(7.8)	13	21	27	31	34	37	40	42	44	46	48	49	51	52	53	55	56		
9.0										5450	5050	4900	4900	4850	4850	4850	4850	4850	4850	4900	4950	4950	5000	5000	5050	5050	
										(8.3)	(8.8)	12	20	25	30	33	36	39	41	43	45	46	48	49	51	52	
10												4700	4350	4250	4250	4200	4200	4200	4250	4250	4300	4350	4350	4400	4400	4450	
												(9.3)	(9.8)	12	19	25	29	32	35	37	40	42	43	45	47	48	
11														4050	3800	3700	3700	3700	3700	3750	3800	3800	3850	3850	3900	3900	
														(10.3)	(10.8)	12	19	24	28	31	34	36	38	40	42	44	
12																3550	3350	3250	3300	3300	3350	3400	3400	3450	3450	3500	
																(11.3)	(11.8)	12	18	23	27	30	33	35	37	40	
13																		3150	3000	2950	3000	3000	3050	3050	3100	3100	
																		(12.3)	(12.8)	11	18	22	26	29	32	35	
14																				2850	2700	2700	2700	2750	2800	2800	
																				(13.3)	(13.8)	11	17	22	25	29	
15																						2600	2500	2450	2500	2550	
																						(14.3)	(14.8)	10	17	22	
16.45																								2400	2300	2200	
																								(15.3)	(15.8)	(16.5)	

MAC-25 OFFSET HEAD TOP POSITION LOAD CHART - 40 DEG

LMI DUTY

304

STANDARD 1500 KG COUNTERWEIGHT (PLMXF2009) + EXTRA 2160 KG COUNTERWEIGHT (PLMXF2019-) ON REAR OF CRANE - SPRING LOCKOUTS ENGAGED

RC IN KILOGRAMS FOR SLEW ANGLES OF GREATER THAN 10 DEGREES UP TO 40 DEGREES EITHER SIDE OF STRAIGHT AHEAD (INDICATED BY RED LED ON DASH).
BOOM ANGLE - UNDEFLECTED (REF.)

RC ABOVE BOLD RED LINE ARE STRUCTURAL
 RC ARE BASED ON FIRM LEVEL GROUND (1% SLOPE (0.6 DEG) AS PER AS1418.5) WITH TYRES INFLATED AS PER NOTES

NOTE: VALUES IN BRACKETS () ARE ACTUAL RADIUS AT ZERO DEG. BOOM ANGLE.
 RC ARE BASED ON 66.6% STABILITY & STRENGTH

LIFT & CARRY - THE RC SHALL BE CARRIED WITH THE MINIMUM BOOM LENGTH & AS CLOSE TO THE GROUND AS POSSIBLE AT SPEEDS NOT IN EXCESS OF 0.4 m/s (1.44 km/h)

Radius in Metres	BOOM PIVOT TO EDGE OF SHEAVE - THIRD BOOM RETRACTED (metres)																	THIRD BOOM EXTENDING (metres)										
	6.82	7.00	7.50	8.00	8.50	9.00	9.50	10.00	10.50	11.00	11.50	12.00	12.50	13.00	13.50	14.00	14.50	15.02	15.50	16.00	16.50	17.00	17.50	18.00	18.50	19.12		
1.4	8400	8400	8400	8400	8400	8400	8400																					
	52	53	56	58	60	62	64																					
2.0	8400	8400	8400	8400	8400	8400	8400	8400	8400	8400												WINCH RC						
	45	47	50	53	56	58	60	61	63	64																SINGLE PART		4200
2.5	8400	8400	8400	8400	8400	8400	8400	8400	8400	8400	8400	8400										TWO PARTS		8400				
	39	41	45	49	52	54	56	58	60	61	63	64																
3.0	8400	8400	8400	8400	8400	8400	8400	8400	8400	8400	8400	8400	8400	8350	8100													
	32	34	40	44	47	50	53	55	57	58	60	61	63	64	65													
3.5	8400	8400	8400	8400	8400	8400	8400	8400	8400	8400	8400	8400	8100	7800	7550	7350	7100											
	24	27	33	38	42	46	49	51	53	55	57	59	60	61	62	63	64											
4.0	8400	8400	8400	8400	8400	8400	8400	8400	8400	8150	7850	7600	7300	7100	6850	6650	6450	6350										
	(4.1)	16	26	32	37	41	45	47	50	52	54	56	57	59	60	61	62	63	64									
5.0	8400	8400	8400	8400	8400	8400	8100	7750	7500	7200	6950	6700	6450	6250	6050	5900	5700	5600	5500	5400	5300	5200	5100					
	(4.3)	(4.8)	15	24	30	35	39	42	45	48	50	52	53	55	56	58	59	60	61	62	63	64	65					
6.0			8400	7500	7200	7200	7100	6800	6550	6300	6100	5950	5750	5550	5400	5200	5050	5000	4900	4800	4750	4650	4600	4500	4400			
			(5.3)	(5.8)	14	23	29	34	37	40	43	46	48	50	51	53	54	56	57	58	59	60	61	62	63			
7.0					6800	6150	5950	5900	5850	5600	5400	5250	5100	4950	4800	4650	4550	4450	4400	4300	4250	4200	4100	4050	4000			
					(6.3)	(6.8)	14	22	28	32	36	39	41	44	46	48	50	51	53	54	55	56	57	58	59			
8.0							5650	5150	5000	5000	4900	4700	4550	4400	4300	4150	4050	4000	3950	3900	3800	3750	3700	3650	3600			
							(7.3)	(7.8)	13	21	27	31	34	37	40	42	44	46	48	49	51	52	53	55	56			
9.0										4750	4400	4250	4250	4150	4000	3850	3750	3650	3600	3550	3500	3450	3400	3400	3350	3300		
										(8.3)	(8.8)	12	20	25	30	33	36	39	41	43	45	46	48	49	51	52		
10											4050	3750	3650	3650	3550	3400	3300	3250	3200	3200	3150	3100	3100	3050	3000			
											(9.3)	(9.8)	12	19	25	29	32	35	37	40	42	43	45	47	48			
11													3500	3250	3150	3150	3050	3000	2950	2900	2850	2850	2800	2800	2750			
													(10.3)	(10.8)	12	19	24	28	31	34	36	38	40	42	44			
12															3050	2850	2750	2800	2700	2650	2650	2600	2550	2550	2500			
															(11.3)	(11.8)	12	18	23	27	30	33	35	37	40			
13																	2650	2550	2500	2500	2450	2400	2400	2350	2300			
																	(12.3)	(12.8)	11	18	22	26	29	32	35			
14																			2400	2300	2300	2300	2200	2200	2150			
																			(13.3)	(13.8)	11	17	22	25	29			
15																					2200	2100	2100	2050	2000			
																					(14.3)	(14.8)	10	17	22			
16.45																							2000	1950	1850			
																							(15.3)	(15.8)	(16.5)			

MAC-25 3m FLYJIB TOP POSITION AT 0 DEG OFFSET LOAD CHART

LMI DUTY

305

COUNTERWEIGHT ON REAR OF CRANE - SPRING LOCKOUTS ENGAGED

PIVOT TO FLY JIB MAX LENGTH 21.4m	
MAX RADIUS	SWL
6.10	1500
	65
7.76	1500
	60
9.34	1200
	55
10.83	1200
	50
12.22	970
	45
13.49	970
	40
14.65	850
	35
15.67	850
	30
16.55	770
	25
17.29	770
	20
17.88	750
	15
18.31	750
	10
18.58	750
	5
18.69	750
	0



S.W.L IN KILOGRAMS FOR SLEW ANGLES UP TO 40 DEGREES EITHER SIDE OF STRAIGHT AHEAD (INDICATED BY RED LED ON DASH).



BOOM ANGLE - UNDEFLECTED (REF.)

NOTE : VALUES IN BRACKETS () ARE ACTUAL RADIUS AT ZERO DEG. BOOM ANGLE.
SWL IS AT THIS RADIUS

SPRING LOCKOUTS ARE TO BE ENGAGED FOR ALL LIFTING OPERATIONS

S.W.L. ARE BASED ON 66.6% STABILITY & STRENGTH

ALL FLYJIB S.W.L.'S ARE STRUCTURAL

S.W.L. ARE BASED ON FIRM LEVEL GROUND (1% SLOPE (0.6 DEG) AS PER AS1418.5)

WITH TYRES INFLATED AS PER NOTES

LIFT & CARRY - THE S.W.L. SHALL BE CARRIED WITH THE MINIMUM BOOM LENGTH & AS

CLOSE TO THE GROUND AS POSSIBLE AT SPEEDS NOT IN EXCESS OF 0.4 M/SEC (1.44 KM/HR)

FLYJIB S.W.L.'S AND RADII ARE BASED ON FULLY EXTENDED BOOM.

FOR OPERATION WITH THE BOOM PART OR FULLY RETRACTED

THE SWL WILL BE BASED ON THE BOOM ANGLE, NOT THE ACTUAL RADIUS.

NOTE : WEIGHT OF HOOKS, BLOCKS & OTHER
LOAD HANDLING DEVICES SHALL BE ADDED
TO THE WEIGHT OF THE LOAD

PIVOT TO FLY JIB MAX LENGTH 21.4m	
MAX RADIUS	SWL
6.60	1300
	65
8.23	1300
	60
9.78	1120
	55
11.24	1120
	50
12.59	920
	45
13.83	920
	40
14.94	820
	35
15.92	820
	30
16.76	770
	25
17.45	770
	20
17.99	750
	15
18.37	750
	10
18.59	750
	5
18.65	750
	0



S.W.L IN KILOGRAMS FOR SLEW ANGLES UP TO 40 DEGREES EITHER SIDE OF STRAIGHT AHEAD (INDICATED BY RED LED ON DASH).



BOOM ANGLE - UNDEFLECTED (REF.)

NOTE: VALUES IN BRACKETS () ARE ACTUAL RADIUS AT ZERO DEG. BOOM ANGLE.
 SWL IS AT THIS RADIUS

SPRING LOCKOUTS ARE TO BE ENGAGED FOR ALL LIFTING OPERATIONS

S.W.L. ARE BASED ON 66.6% STABILITY & STRENGTH

ALL FLYJIB S.W.L.'S ARE STRUCTURAL

S.W.L. ARE BASED ON FIRM LEVEL GROUND (1% SLOPE (0.6 DEG) AS PER AS1418.5)

WITH TYRES INFLATED AS PER NOTES

LIFT & CARRY - THE S.W.L. SHALL BE CARRIED WITH THE MINIMUM BOOM LENGTH & AS CLOSE TO THE GROUND AS POSSIBLE AT SPEEDS NOT IN EXCESS OF 0.4 M/SEC (1.44 KM/HR)

FLYJIB S.W.L.'S AND RADII ARE BASED ON FULLY EXTENDED BOOM.

FOR OPERATION WITH THE BOOM PART OR FULLY RETRACTED

THE SWL WILL BE BASED ON THE BOOM ANGLE, NOT THE ACTUAL RADIUS.

**NOTE : WEIGHT OF HOOKS, BLOCKS & OTHER
 LOAD HANDLING DEVICES SHALL BE ADDED
 TO THE WEIGHT OF THE LOAD**

MAC-25 4m FLYJIB TOP POSITION AT 5 DEG OFFSET LOAD CHART

LMI DUTY

307

COUNTERWEIGHT ON REAR OF CRANE - SPRING LOCKOUTS ENGAGED

PIVOT TO FLY JIB MAX LENGTH 22.48m	
MAX RADIUS	SWL
6.85	700
	65
8.58	600
	60
10.23	600
	55
11.77	600
	50
13.21	600
	45
14.53	500
	40
15.72	500
	35
16.77	500
	30
17.67	500
	25
18.42	500
	20
19.00	500
	15
19.43	500
	10
19.68	500
	5
19.77	500
	0



S.W.L IN KILOGRAMS FOR SLEW ANGLES UP TO 40 DEGREES EITHER SIDE OF STRAIGHT AHEAD (INDICATED BY RED LED ON DASH).



BOOM ANGLE - UNDEFLECTED (REF.)

NOTE : VALUES IN BRACKETS () ARE ACTUAL RADIUS AT ZERO DEG. BOOM ANGLE.
SWL IS AT THIS RADIUS

SPRING LOCKOUTS ARE TO BE ENGAGED FOR ALL LIFTING OPERATIONS

S.W.L. ARE BASED ON 66.6% STABILITY & STRENGTH

ALL FLYJIB S.W.L.'S ARE STRUCTURAL

S.W.L. ARE BASED ON FIRM LEVEL GROUND (1% SLOPE (0.6 DEG) AS PER AS1418.5)

WITH TYRES INFLATED AS PER NOTES

LIFT & CARRY - THE S.W.L. SHALL BE CARRIED WITH THE MINIMUM BOOM LENGTH & AS CLOSE TO THE GROUND AS POSSIBLE AT SPEEDS NOT IN EXCESS OF 0.4 M/SEC (1.44 KM/HR)

FLYJIB S.W.L.'S AND RADII ARE BASED ON FULLY EXTENDED BOOM.
FOR OPERATION WITH THE BOOM PART OR FULLY RETRACTED
THE SWL WILL BE BASED ON THE BOOM ANGLE, NOT THE ACTUAL RADIUS.

NOTE : WEIGHT OF HOOKS, BLOCKS & OTHER
LOAD HANDLING DEVICES SHALL BE ADDED
TO THE WEIGHT OF THE LOAD

MAC-25 4m FLYJIB BOTTOM POSITION AT 17.5 DEG OFFSET LOAD CHART

LMI DUTY

308

COUNTERWEIGHT ON REAR OF CRANE - SPRING LOCKOUTS ENGAGED

PIVOT TO FLY JIB MAX LENGTH 22.41m	
MAX RADIUS	SWL
7.82	600
	65
9.50	600
	60
11.09	600
	55
12.57	500
	50
13.94	500
	45
15.18	500
	40
16.29	500
	35
17.25	500
	30
18.07	500
	25
18.72	500
	20
19.22	500
	15
19.55	500
	10
19.70	500
	5
19.70	500
	0



S.W.L IN KILOGRAMS FOR SLEW ANGLES UP TO 40 DEGREES EITHER SIDE OF STRAIGHT AHEAD (INDICATED BY RED LED ON DASH).



BOOM ANGLE - UNDEFLECTED (REF.)

NOTE : VALUES IN BRACKETS () ARE ACTUAL RADIUS AT ZERO DEG. BOOM ANGLE.
SWL IS AT THIS RADIUS

SPRING LOCKOUTS ARE TO BE ENGAGED FOR ALL LIFTING OPERATIONS

S.W.L. ARE BASED ON 66.6% STABILITY & STRENGTH

ALL FLYJIB S.W.L.'S ARE STRUCTURAL

S.W.L. ARE BASED ON FIRM LEVEL GROUND (1% SLOPE (0.6 DEG) AS PER AS1418.5)

WITH TYRES INFLATED AS PER NOTES

LIFT & CARRY - THE S.W.L. SHALL BE CARRIED WITH THE MINIMUM BOOM LENGTH & AS

CLOSE TO THE GROUND AS POSSIBLE AT SPEEDS NOT IN EXCESS OF 0.4 M/SEC (1.44 KM/HR)

FLYJIB S.W.L.'S AND RADII ARE BASED ON FULLY EXTENDED BOOM.

FOR OPERATION WITH THE BOOM PART OR FULLY RETRACTED

THE SWL WILL BE BASED ON THE BOOM ANGLE, NOT THE ACTUAL RADIUS.

NOTE : WEIGHT OF HOOKS, BLOCKS & OTHER
LOAD HANDLING DEVICES SHALL BE ADDED
TO THE WEIGHT OF THE LOAD

MAXIMUM MANBASKET SWL: 275 KG (SEE NOTE BELOW)
BASKET WEIGHT: 225 KG

*Read and understand warning notes before
operating crane*

**NOTE: THE TOTAL WEIGHT OF THE MANBASKET PLUS
MEN AND EQUIPMENT IS NOT TO EXCEED 1/3 OF
THE SAFE WORKING LOAD AS READ ON LOAD
CHART (FALL BLOCK LOAD CHART - DUTY 201)
FOR THE BOOM LENGTH AND RADIUS BEING USED.**

MAC-25 BUTT LUG - 10 DEG. ART.**STANDARD 1500 KG COUNTERWEIGHT (PLMXF2009)****+ EXTRA 2160 KG COUNTERWEIGHT (PLMXF2019-) ON REAR OF CRANE - SPRING LOCKOUTS ENGAGED**

RC IN KILOGRAMS FOR SLEW ANGLES OF 10 DEGREES OR LESS EITHER SIDE OF STRAIGHT AHEAD (INDICATED BY GREEN LED ON DASH).



BOOM ANGLE - UNDEFLECTED (REF.)

NOTE: VALUES IN BRACKETS () ARE ACTUAL RADIUS AT ZERO DEG. BOOM ANGLE. RC IS AT THIS RADIUS**MAC-25 BUTT LUG - 40 DEG. ART.**

RC IN KILOGRAMS FOR SLEW ANGLES OF GREATER THAN 10 DEGREES UP TO 40 DEGREES EITHER SIDE OF STRAIGHT AHEAD (INDICATED BY RED LED ON DASH).



BOOM ANGLE - UNDEFLECTED (REF.)

NOTE: VALUES IN BRACKETS () ARE ACTUAL RADIUS AT ZERO DEG. BOOM ANGLE. RC IS AT THIS RADIUS

RC ARE BASED ON 66.6% STABILITY & STRENGTH - RC ABOVE BOLD RED LINE ARE STRUCTURAL

RC ARE BASED ON FIRM, LEVEL GROUND (1% SLOPE (0.6 DEG) AS PER AS1418.5) WITH TYRES INFLATED AS PER NOTES

LIFT & CARRY - THE RC SHALL BE CARRIED WITH THE MINIMUM BOOM LENGTH & AS CLOSE TO THE GROUND AS POSSIBLE AT SPEEDS NOT IN EXCESS OF 0.4 m/s (1.44 km/h)

NOTE: WEIGHT OF HOOKS, BLOCKS & OTHER LOAD HANDLING DEVICES SHALL BE ADDED TO THE WEIGHT OF THE LOAD

Radius in Metres	Boom Length (metres)
	4.81
1.4	25000
	32
1.5	25000
	30
1.6	24650
	27
1.7	24200
	24
1.8	23800
	21
1.9	23400
	18
2.1	22600
	0

NOTE : WEIGHT OF HOOKS, BLOCKS & OTHER LOAD HANDLING DEVICES SHALL BE ADDED TO THE WEIGHT OF THE LOAD

Radius in Metres	Boom Length (metres)
	4.81
1.4	25000
	32
1.5	25000
	30
1.6	24650
	27
1.7	24200
	24
1.8	23800
	21
1.9	23400
	18
2.1	22050
	0

MAC25 LUG 1 LOAD CHART - 10 DEG. ART.

STANDARD 1500 KG COUNTERWEIGHT (PLMXF2009)

+ EXTRA 2160 KG COUNTERWEIGHT (PLMXF2019-) ON REAR OF CRANE - SPRING LOCKOUTS ENGAGED



RC IN KILOGRAMS FOR SLEW ANGLES OF 10 DEGREES OR LESS EITHER

SIDE OF STRAIGHT AHEAD (INDICATED BY GREEN LED ON DASH).



BOOM ANGLE - UNDEFLECTED (REF.)

NOTE: VALUES IN BRACKETS () ARE ACTUAL RADIUS AT ZERO DEG. BOOM ANGLE
RC IS AT THIS RADIUS

MAC25 LUG 1 LOAD CHART - 40 DEG. ART.



RC IN KILOGRAMS FOR SLEW ANGLES OF GREATER THAN 10 DEGREES UP TO 40

DEGREES EITHER SIDE OF STRAIGHT AHEAD (INDICATED BY RED LED ON DASH).



BOOM ANGLE - UNDEFLECTED (REF.)

NOTE: VALUES IN BRACKETS () ARE ACTUAL RADIUS AT ZERO DEG. BOOM ANGLE
RC IS AT THIS RADIUS

RC ARE BASED ON 66.6% STABILITY & STRENGTH - RC ABOVE BOLD RED LINE ARE STRUCTURAL

RC ARE BASED ON FIRM, LEVEL GROUND (1% SLOPE (0.6 DEG) AS PER AS1418.5) WITH TYRES INFLATED AS PER NOTES

LIFT & CARRY - THE RC SHALL BE CARRIED WITH THE MINIMUM BOOM LENGTH & AS CLOSE TO THE GROUND AS POSSIBLE AT SPEEDS NOT IN EXCESS OF 0.4 m/s (1.44 km/h)

NOTE : WEIGHT OF HOOKS, BLOCKS & OTHER LOAD HANDLING DEVICES SHALL BE ADDED TO THE WEIGHT OF THE LOAD

RADIUS IN METRES	BOOM PIVOT TO LUG 1, 1st EXTENSION, THIRD EXTENSION RETRACTED (metres)									
	5.36	5.50	6.00	6.50	7.00	7.50	8.00	8.50	9.00	9.46
1.4	25000	25000	25000	25000	25000	25000	25000	25000	25000	24000
	40	42	47	51	54	57	59	61	63	64
2	23900	23850	23650	23500	23300	23150	22950	22750	22600	21350
	29	31	38	44	48	51	54	56	59	60
2.5	21000	20950	20700	20450	20250	20050	19900	19750	19600	19500
	14	19	30	37	42	46	49	52	55	57
3	18600	18000	16900	16700	16550	16400	16250	16100	16000	15900
	(2.7)	(2.8)	18	29	35	41	45	48	51	53
3.5			15200	14050	13900	13750	13600	13500	13400	13300
			(3.3)	17	28	34	39	43	46	49
4				12750	11900	11750	11650	11550	11450	11350
				(3.8)	17	27	33	38	42	45
5					10850	9350	8850	8800	8700	8650
					(4.3)	(4.8)	16	25	31	36
6							8150	7150	6850	6800
							(5.3)	(5.8)	15	23
6.8									6300	5650
									(6.3)	(6.8)

RADIUS IN METRES	BOOM PIVOT TO LUG 1, 1st EXTENSION, THIRD EXTENSION RETRACTED (metres)									
	5.36	5.50	6.00	6.50	7.00	7.50	8.00	8.50	9.00	9.46
1.4	22600	21750	19350	17600	16150	15000	14000	13200	12450	11800
	40	42	47	51	54	57	59	61	63	64
2	23800	22900	18750	16600	15050	13850	12850	12000	11300	10700
	29	31	38	44	48	51	54	56	59	60
2.5	18700	18650	18400	16800	14250	13000	11950	11150	10450	9900
	14	19	30	37	42	46	49	52	55	57
3	17500	16450	15000	14800	13950	12950	11200	10350	9650	9150
	(2.7)	(2.8)	18	29	35	41	45	48	51	53
3.5			13450	12400	12250	11750	10950	9650	8950	8450
			(3.3)	17	28	34	39	43	46	49
4				11200	10450	10350	10000	9350	8800	7850
				(3.8)	17	27	33	38	42	45
5					9500	8150	7700	7650	7400	7000
					(4.3)	(4.8)	16	25	31	36
6							7050	6150	5900	5850
							(5.3)	(5.8)	15	23
6.8									5400	4800
									(6.3)	(6.8)

THIS PAGE HAS BEEN
INTENTIONALLY LEFT BLANK

MAC-25 LUG 2 LOAD CHART - 10 DEG. ART.

LMI DUTY

312

STANDARD 1500 KG COUNTERWEIGHT (PLMXF2009)

+ EXTRA 2160 KG COUNTERWEIGHT (PLMXF2019-) ON REAR OF CRANE - SPRING LOCKOUTS ENGAGED



RC IN KILOGRAMS FOR SLEW ANGLES OF 10 DEGREES OR LESS EITHER

RC ARE BASED ON 66.6% STABILITY & STRENGTH

SIDE OF STRAIGHT AHEAD (INDICATED BY GREEN LED ON DASH).

RC ABOVE BOLD RED LINE ARE STRUCTURAL



BOOM ANGLE - UNDEFLECTED (REF.)

RC ARE BASED ON FIRM LEVEL GROUND (1% SLOPE (0.6 DE

NOTE: VALUES IN BRACKETS () ARE ACTUAL RADIUS AT ZERO DEG. BOOM ANGLE.

AS PER AS1418.5) WITH TYRES INFLATED AS PER NOTES

ENSURE WINCH ROPE IS FULLY TENSIONED

LIFT & CARRY - THE RC SHALL BE CARRIED WITH THE MINIMUM BOOM LENGTH & AS

CLOSE TO THE GROUND AS POSSIBLE AT SPEEDS NOT IN EXCESS OF 0.4 m/s (1.44 km/h)

BOOM PIVOT TO LUG 2, 2nd EXTENSION, THIRD EXTENSION RETRACTED

Radius in Metres	(metres)																	
	5.57	6.00	6.50	7.00	7.50	8.00	8.50	9.00	9.50	10.00	10.50	11.00	11.50	12.00	12.50	13.00	13.50	13.77
1.4	25000	25000	25000	25000	25000	25000	25000	25000	25000									
	42	46	50	54	57	59	61	63	64									
2	24150	24100	24000	23950	23900	23850	23800	23700	23650	23600	21850	19400						
	32	38	43	47	51	54	56	58	60	62	63	64						
2.5	21150	21150	21150	21100	21100	21050	21050	21050	21000	19950	17700	16550	15650					
	20	29	36	42	46	49	52	54	57	58	60	62	63	64				
3	17900	17350	17350	17350	17300	17300	17300	17300	17250	17250	17250	16300	15200	14400	13600	12900		
	(2.9)	18	28	35	40	44	48	50	53	55	57	59	60	61	63	64		
3.5		15600	14650	14650	14650	14600	14600	14600	14600	14550	14550	14550	14050	13300	12600	11900	11250	10900
		(3.3)	17	27	34	39	43	46	49	51	54	55	57	59	60	61	62	63
4			13350	12600	12600	12600	12600	12600	12550	12550	12550	12550	12550	12350	11700	11050	10450	10150
			(3.8)	16	26	33	38	42	45	48	50	52	54	56	57	59	60	61
5				11600	10200	9750	9750	9750	9750	9750	9750	9750	9700	9700	9700	9650	9100	8800
				(4.3)	(4.8)	15	25	31	36	39	43	45	48	50	52	53	55	56
6						9050	8150	7850	7850	7850	7850	7850	7850	7850	7850	7850	7850	7800
						(5.3)	(5.8)	14	23	29	34	37	41	43	46	48	50	51
7								7350	6700	6500	6500	6500	6500	6500	6500	6500	6500	6500
								(6.3)	(6.8)	14	22	28	32	36	39	42	44	45
8										6100	5600	5500	5500	5500	5500	5500	5500	5500
										(7.3)	(7.8)	13	21	27	31	34	37	39
9												5150	4750	4700	4700	4700	4700	4700
												(8.3)	(8.8)	12	20	26	30	32
10														4450	4100	4050	4050	4050
														(9.3)	(9.8)	12	19	23
11																3850	3550	3550
																(10.3)	(10.8)	6
11.1																		3450
																		(11.1)

**NOTE : WEIGHT OF HOOKS, BLOCKS & OTHER
LOAD HANDLING DEVICES SHALL BE ADDED
TO THE WEIGHT OF THE LOAD**

AFTERMARKET DEPARTMENT KEY CONTACTS LIST

National Technical Support Contact 24/7

PH: 1800 837 395 (1800TEREXL)

Aftermarket Manager

Ph: +64 7 3868 9674

Customer Service Manager

Ph: +64 7 3868 9690

MANAGERS

Spare Parts	Product Support	Service	Warranty
+64 7 3868 9652	+64 7 3868 9655	+64 7 3868 9690	+64 7 3868 9657

SERVICE CONTACTS

QLD	NSW	VIC	WA
+64 7 3868 9600	+64 2 8786 4400	+64 3 9551 9164	+64 8 6254 2145

SPARE PARTS CONTACTS

QLD	NSW	VIC	WA
+64 7 3868 9600	+64 2 8786 4404	+64 3 9551 8644	+64 8 6254 2145

Please have the following information available before calling:

- ✓ Company name, contact name, phone number and e-mail
- ✓ Crane model and serial number
- ✓ Crane hours and kilometers

**A FULL LIST OF CONTACTS IS AVAILABLE ON REQUEST
PLEASE CALL YOUR NEAREST BRANCH OFFICE**

MAC-25 LUG 2 LOAD CHART - 40 DEG. ART.

LMI DUTY

312

STANDARD 1500 KG COUNTERWEIGHT (PLMXF2009)

+ EXTRA 2160 KG COUNTERWEIGHT (PLMXF2019)- ON REAR OF CRANE - SPRING LOCKOUTS ENGAGED



RC IN KILOGRAMS FOR SLEW ANGLES OF GREATER THAN 10 DEGREES UP TO 40 DEGREES EITHER SIDE OF STRAIGHT AHEAD (INDICATED BY RED LED ON DASH).

RC ARE BASED ON 66.6% STABILITY & STRENGTH

RC ABOVE BOLD RED LINE ARE STRUCTURAL



BOOM ANGLE - UNDEFLECTED (REF.)

RC ARE BASED ON FIRM LEVEL GROUND (1% SLOPE (0.6 DE

NOTE: VALUES IN BRACKETS () ARE ACTUAL RADIUS AT ZERO DEG. BOOM ANGLE.

AS PER AS1418.5) WITH TYRES INFLATED AS PER NOTES

ENSURE WINCH ROPE IS FULLY TENSIONED

LIFT & CARRY - THE RC SHALL BE CARRIED WITH THE MINIMUM BOOM LENGTH & AS CLOSE TO THE GROUND AS POSSIBLE AT SPEEDS NOT IN EXCESS OF 0.4 m/s (1.44 km/h)

BOOM PIVOT TO LUG 2, 2nd EXTENSION, THIRD EXTENSION RETRACTED

Radius in Metres	BOOM PIVOT TO LUG 2, 2nd EXTENSION, THIRD EXTENSION RETRACTED (metres)																	
	5.57	6.00	6.50	7.00	7.50	8.00	8.50	9.00	9.50	10.00	10.50	11.00	11.50	12.00	12.50	13.00	13.50	13.77
1.4	21500	19650	18000	16700	15650	14750	13950	13250	12650									
	42	46	50	54	57	59	61	63	64									
2	22700	19050	17050	15650	14500	13600	12850	12200	11600	11100	10650	10200						
	32	38	43	47	51	54	56	58	60	62	63	64						
2.5	18850	18850	17400	14900	13700	12800	12050	11400	10850	10350	9900	9500	9150	8850				
	20	29	36	42	46	49	52	54	57	58	60	62	63	64				
3	16200	15400	15450	14700	13800	12050	11300	10650	10100	9650	9250	8850	8550	8250	7950	7700		
	(2.9)	18	28	35	40	44	48	50	53	55	57	59	60	61	63	64		
3.5		13850	13000	13000	12600	11900	10600	10000	9450	9000	8650	8300	7950	7700	7400	7200	6950	6850
		(3.3)	17	27	34	39	43	46	49	51	54	55	57	59	60	61	62	63
4			11800	11150	11150	10950	10350	9400	8900	8450	8100	7750	7450	7200	6950	6700	6500	6400
			(3.8)	16	26	33	38	42	45	48	50	52	54	56	57	59	60	61
5				10250	9000	8600	8600	8500	8100	7750	7500	6850	6550	6350	6100	5900	5750	5650
				(4.3)	(4.8)	15	25	31	36	39	43	45	48	50	52	53	55	56
6					8000	7150	6900	6900	6800	6500	6300	6050	5600	5400	5250	5100	5000	
					(5.3)	(5.8)	14	23	29	34	37	41	43	46	48	50	51	
7								6450	5850	5650	5700	5600	5350	5200	5000	4700	4550	4450
								(6.3)	(6.8)	14	22	28	32	36	39	42	44	45
8										5300	4850	4750	4750	4650	4500	4350	4200	4150
										(7.3)	(7.8)	13	21	27	31	34	37	39
9												4450	4100	4050	4050	3950	3800	3750
												(8.3)	(8.8)	12	20	26	30	32
10														3800	3500	3500	3500	3400
														(9.3)	(9.8)	12	19	23
11																3250	3050	3000
																(10.3)	(10.8)	6
11.1																		2900
																		(11.1)

NOTE : WEIGHT OF HOOKS, BLOCKS & OTHER LOAD HANDLING DEVICES SHALL BE ADDED TO THE WEIGHT OF THE LOAD